

BASE II 'LEVER' RFID (E9 Series) Electronic Hotel Lock

Be-Tech BASE II 'LEVER' RFID is a stylish cylindrical latch solution. It combines modern design and expert engineering to present a multifaceted security option that fits seamlessly into back-of-house security blueprint providing upgraded life safety and property security. It seamlessly integrates with existing Be-Tech installations.

Be-Tech BASE II 'LEVER' RFID is ideal for upgrading existing mechanical locking systems or for improving back-of-house controls. It's based on the same product platform as Be-Tech RFID locking system. Thus it is compatible with BIS HOTEL software platform.

Features:

- Stand alone electronic lock with RFID technology.
- Easily replaces existing mechanical lever-set or knob-set without any carpentry.
- 60/70mm backset adjustable tubular latch.
- ANSI/BHMA Grade 3 approved tubular latch.
- Brushed stainless steel finish with higher anti-corrosion performance.
- Anti-panic exit system - For convenience and in case of emergency, it allows you to open the door by simply turning its handle from inside.
- ADA compliant (guest with physical disabilities).
- Future proof re-programmable FLASH RAM lock memory.
- Powered by four AA batteries that provide up to 1 year normal life time.
- 414 events audit trail.
- Compatible with BIS HOTEL software platform.
- Compatible hotel function and residential function.



RFID Specifications:

- 13.56MHz technology
- Compatible with the following standard : ISO 14443 A (MIFARE Classic)
- Eleven free sectors for future All-in-one card application use

Dimensions:

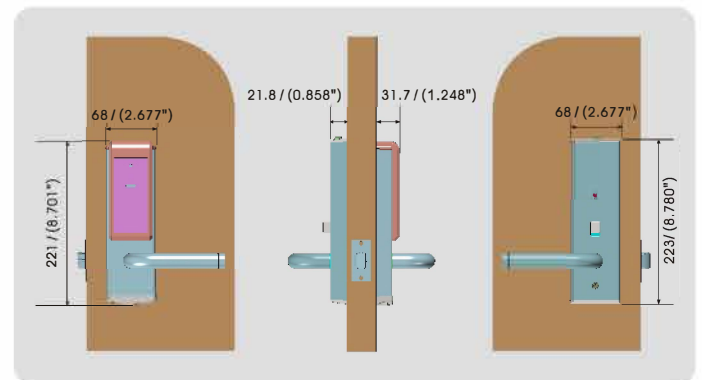

BASE II 'LEVER' RFID series is not suitable for outdoor.

Distributor for India

CitiSolutions Hospitality Products Pvt Ltd
Bangalore
www.citisolutionshospitality.com

Mobile No +91 9980018277



Focus on Smart Lock Since 1992.

Technical Data:

Power	4 x 1.5V AA alkaline batteries
Battery Location	Inside of the back lock
Material	Handles: Stainless steel quality SUS304 Lock body: Stainless steel quality SUS304
Metal Finishes	Silver, Matte Black
Emergency Opening Options	Emergency Opening with Mechanical cylinder
Locking Mechanism	Electro-mechanical locking mechanism
Door Thickness	35-60mm (only for EURO mortise)
System Software Compatibility	BIS Hotel
Storage Temperature	Workable -20°C~60°C: non-condensing environment
Tested Operating Temperature	Tested from -25°C~70°C
Supported RFID Standard	ISO 14443 A (MIFARE Classic)



Installation

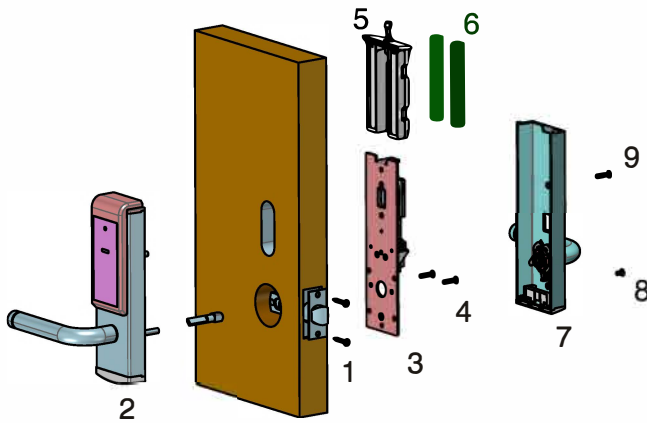

Distributor for India, Nepal, Sri Lanka & Maldives

CitiSolutions Hospitality Products Pvt Ltd
No : 18, 1st Main Byreshwara Laout, Hennur Bande,
Bangalore - 560 043
www.citisolutionshospitality.com

Guangdong Be-Tech Security Systems Limited

No.17, Ronggui Technology Industrial Park

Keyuan 3rd Road, Shunde, Foshan

Guangdong, P.R.China

Tel:+86 757 28376123 | Fax:+86 757 28308823

E-mail:export@be-tech.com.cn | www.betechlock.com

Specifications may change without notice.